



NORTHWOOD

**NORTHWOOD
MANUFACTURING
DEALER
TRAINING MANUAL**



INTRODUCTION:

NORTHWOOD MANUFACTURING



Nestled in the Grande Ronde valley in the mountains of Eastern Oregon, Northwood Manufacturing has

been building a reputation for producing All Condition, 4-Season recreational vehicles of unsurpassed quality and durability for over 25 years.

While Northwood manufactures different brands to appeal to different lifestyles, this single philosophy of "Absolute Northwood" is at the heart of every brand that we build.

That explains why these brands enjoy the endorsement of generations of RV owners and why so many RV enthusiasts aspire to own one.

"Absolute Northwood" is a better idea and a better way to build RVs. "Absolute Northwood" is the heart and soul of each of these highly reputed recreational vehicle brands.

TRAVEL TRAILER BRANDS

ARCTIC FOX
NORTH FORK

NASH

TRUCK CAMPER BRANDS

ARCTIC FOX



FIFTH WHEEL BRANDS

ARCTIC FOX
GRANDE RONDE

FOX
MOUNTAIN

TOY HAULER BRANDS



INTRODUCTION:

NORTHWOOD MANUFACTURING

What does “Absolute Northwood” Mean?

- There is a right way to do things
- There are certain steps and processes which must take place. If you omit or shortcut any of these actions (knowingly or not), you jeopardize the result
- These issues are not negotiable - they are “ABSOLUTE” - regardless of the price point
- Simply put: if you don't build it right - you build it wrong

There are no shortcuts! Quality cannot be added on, it must be designed in

- Design for function
- Use superior engineering
- Use superior processes
- Use superior materials
- Use superior craftsmanship
- Choose Northwood



ABSOLUTE CONCEPT:

BEST-IN-CLASS CHASSIS

WE BUILD OUR OWN CHASSIS

Like the foundation of your home, everything rides on the quality of your chassis. You don't want to worry about cracks, folds, or sags. Chassis failure should never be a concern. Towing your trailer creates similar conditions to an earthquake, a really long earthquake! This shaking and rocking doesn't stop after a minute or two like an earthquake; this stress continues however long your trailer is under tow - hour upon hour, day after day, year after year.

That is why Northwood engineers and constructs our chassis with your safety in mind. We "beef up" our chassis to withstand the stress of towing. So, consequently they are stronger and heavier.

- Northwood Built Proprietary Chassis
- Chassis Specifically Designed for Each Model
- "Rugged-Built" for Off-Road Use

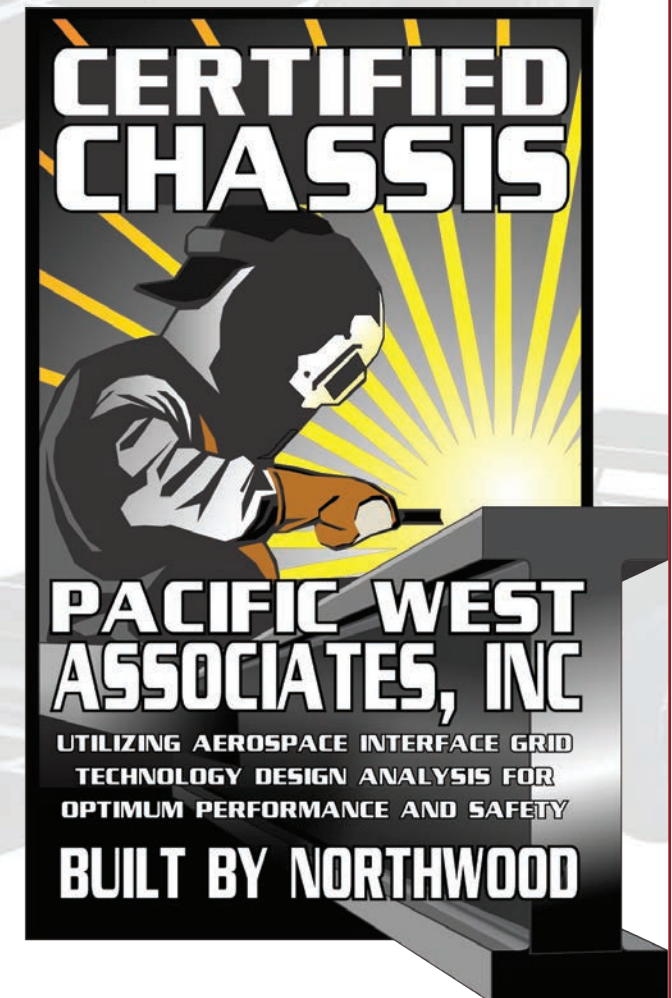

ABSOLUTE CONCEPT:

BEST-IN-CLASS CHASSIS

CERTIFIED CHASSIS

The Industry's First Independently Designed & Tested,
Chassis Utilizing Aerospace Interface Grid Technology
For Optimal Performance and Safety.



Built Exclusively by **NORTHWOOD**

ABSOLUTE CONCEPT:

BEST-IN-CLASS CHASSIS

Cambered Main Rails

- Improves the chassis load bearing attributes
- Prevents sagging chassis
- Directs weight and force to the undercarriage

Structural Steel I-Beam and Channel Rails (8", 10" & 12")

- Can support more load without sagging

Reinforced Web Above Axle Brackets

- Distributes the load vertically across the Main Rail
- Adds structural reinforcement at the point of greatest stress
- Helps reduce the possibility of chassis fold from overloading
- **IMPORTANT: NEVER** overload the chassis past specifications
- Rack and Pinion slide mechanism tubes are supported fully across frame - Stronger and Deeper Slides

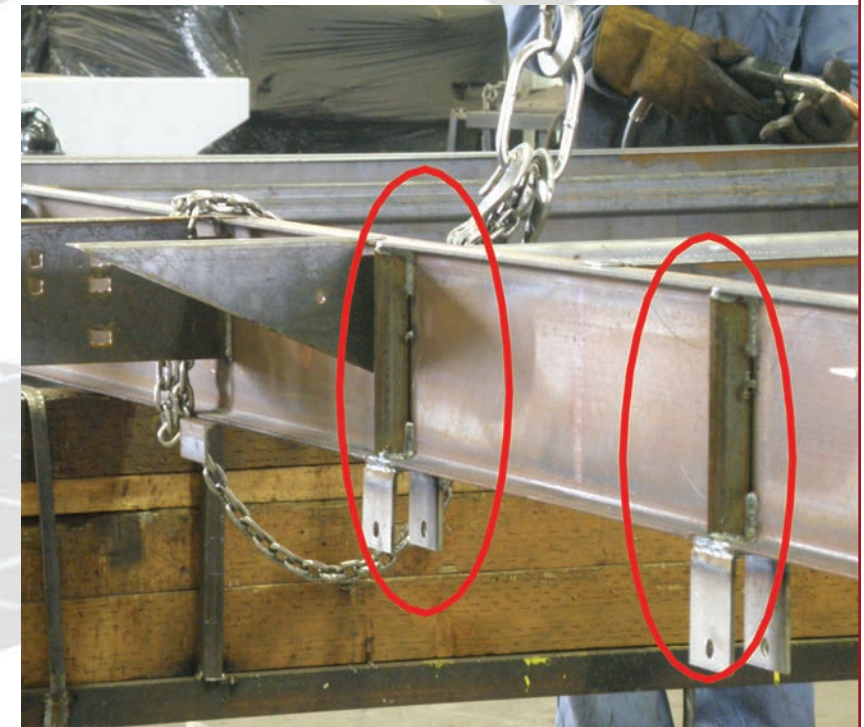
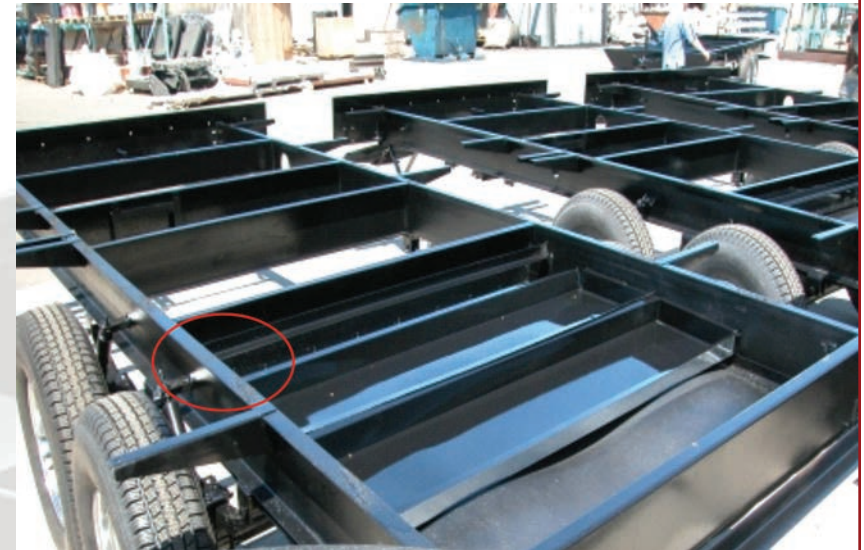

ABSOLUTE CONCEPT:

BEST-IN-CLASS CHASSIS

Pass-Thru Integrated A-Frame (Travel Trailers)

- Structural integrity is “designed in” - not “added on”
- A-Frame is the focal point of all towing tension
- The A-Frame “passes through” the channel front cross member
- Welded: Front, rear and plated to the inside of the main rails
- Increased ground clearance for rugged road conditions

3/4” Steel Gas Manifold

- Mounted within the Main Rail frame
- Located up and away from road hazards
- Heavy gauge black iron pipe is more resistant to damage
- Large diameter - supplies abundant LPG volume to multiple appliances simultaneously
- Better gas flow at higher elevations

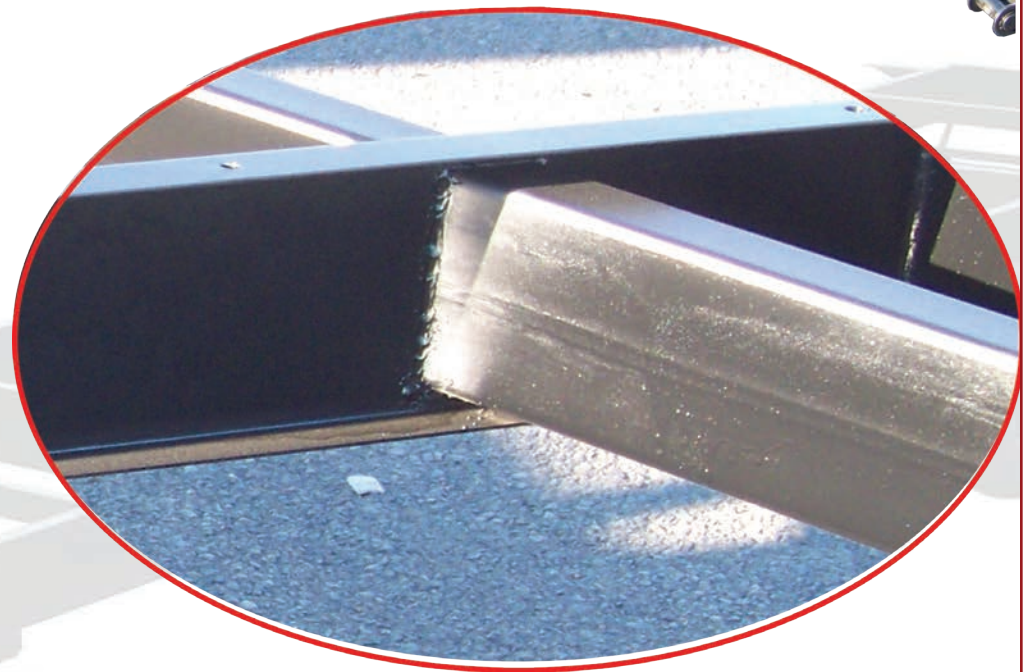
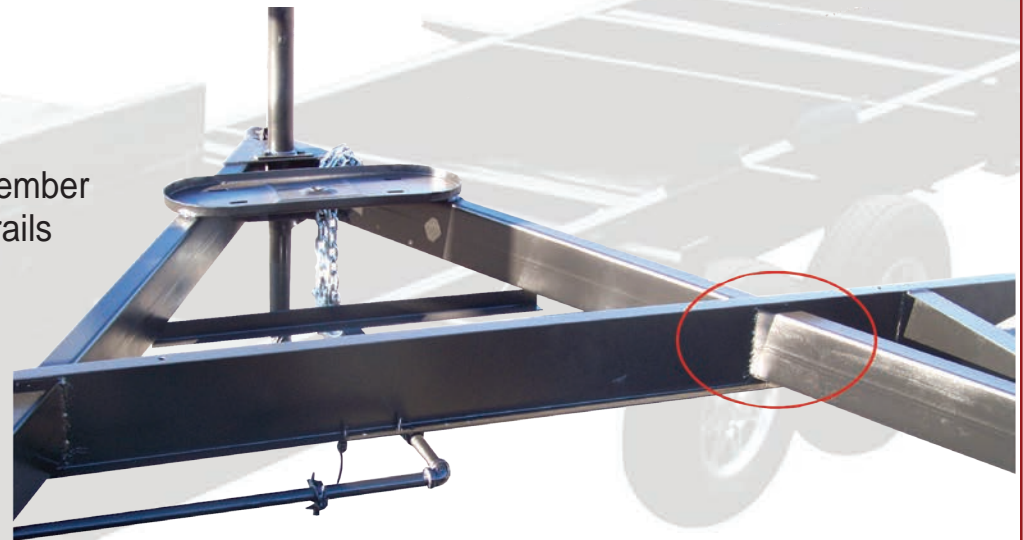

ABSOLUTE CONCEPT:

BEST-IN-CLASS CHASSIS

Welded Stabilizing Jacks, LP Tray, Safety Chains, Exterior Mounted Entry Steps

- Welding is more durable than screws or bolts that can rattle loose

Large Capacity Axles

- Large axles provide optimum carrying capacity
- Up to 7,000 pounds per axle depending on the model

Custom Aluminum Wheels (15" & 16")

- Improved styling and aesthetic
- Rust free, low maintenance and strong



ABSOLUTE CONCEPT:

BEST-IN-CLASS CHASSIS

Higher Load Rated Tires

- Supports the larger capacity of your RV
- G614RST - 'G' Rated Tires for greater load capacity (on 28-5C and larger 5th wheels)

Goodyear Radial Tires

- Made in America
- Trailering Tire - Designed Specifically for towing under load
- Trusted Name Brand
- Nationwide Service Access

GOODYEAR



ABSOLUTE CONCEPT:

BEST-IN-CLASS CHASSIS

E-Z Lube Bearing Lubrication System

- Trusted name brand
- Easy to self-administer
- No mess
- Purges contaminated grease from both the inner and outer bearing without disassembly

Nev-R-Adjust Forward Self-Adjusting Brakes On All Axles

- Trusted name brand
- Reduced stopping distance
- Eliminates cost of manual brake adjustments
- Stop with confidence

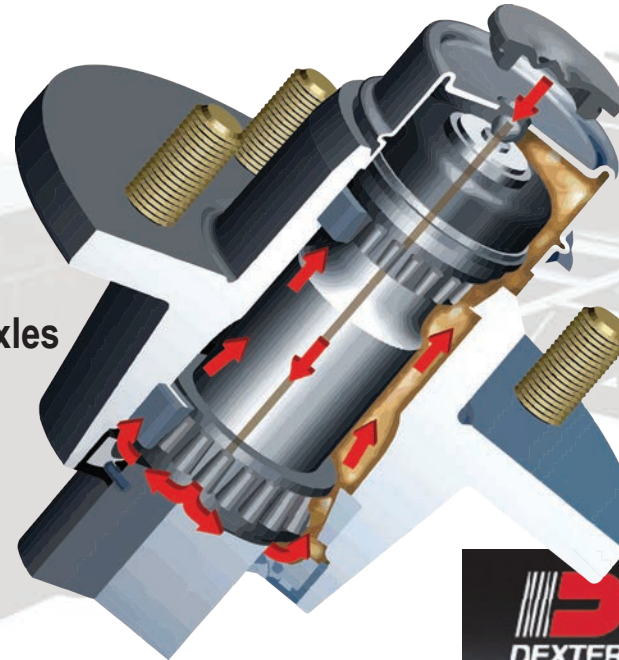

DEXTER AXLE



NEV-R-ADJUST[®]
FORWARD SELF-ADJUSTING ELECTRIC BRAKES



Eliminates manual brake adjustments
Maintains optimum brake adjustment
Saves time and money
Retrofits to existing axles
Made in the U.S.A.
Five-year limited warranty



E-Z LUBE[®]
BEARING LUBRICATION SYSTEM



E-Z bearing lubrication
Replace old grease with new
No disassembly required
TORFLEX[®] and Spring axles up to 8,000 lbs.
Five-year limited warranty

ABSOLUTE CONCEPT:

BEST-IN-CLASS CHASSIS

Suspension & Clearance Considerations for the Adventurous

- Heavy Duty Steel, Leaf Spring Suspension
- Heavy Duty Gas Shock Absorbers on all four wheels on Arctic Fox, Desert Fox & Nash
- Fox Mountain features Equa-Flex Trailair rubberized equalizers
- Arctic Fox features Heavy Duty Shackle Links
- Bronze bushings and multi-point greaseable fittings for lubrication reduces noise and extends life (fifth wheels only)
- 15" heavy duty mud flaps
- 16" wheels on all larger Arctic Fox travel trailers and fifth wheels, Desert Fox toy haulers, and Fox Mountain fifth wheels for even greater ground clearance
- All units are equipped with Goodyear tires developed specifically for use on RVs



**ABSOLUTE
ADVANTAGE**
OFF ROAD RATED
BETTER TOWABILITY

MORryde RPB Fifth Wheel Hitch (Arctic Fox Fifth Wheels)

- Rubberized and pivoting pin box designed to enhance and smooth ride
- Reduced vibration and chucking
- Name brand quality in design and manufacturing
- Provides jerk free starts and stops
- Ensures a more comfortable in-cab ride



Trailair Fifth Wheel Hitch (Fox Mountain)

- Road shock absorbed by rubberized torsion compound
- Powder coated lower jaw
- Reduces back and forth chucking



ABSOLUTE CONCEPT:

ALL CONDITIONS - FOUR SEASONS

Northwood builds a true All Conditions unit that will keep you comfortable, even in extreme summer and winter temperatures. Northwood ALL CONDITIONS RV tells you that they are rated down to 0 degrees Fahrenheit!

Enclosed Plumbing System

There are no exposed plumbing applications - everything is enclosed and protected from harsh climates

- Seamless, durable roto-molded holding tanks
- 1/2" crack resistant Pex pipe
- Pex is pliable, resistant to scale and chlorine, and will not corrode or develop pinholes
- Holding tank knife valves are enclosed in an insulated, heated compartment - protects from freezing
- Enclosed P-Traps

Compartmentalized Chassis Provide Unsurpassed Protection

- Individual, enclosed and sealed compartment for each holding tank
- R7 Batten insulation lines the bottom of each compartment
- Suspended tanks prevent insulation compression
- "Fox Hole" heat vents circulate warm air around the tanks

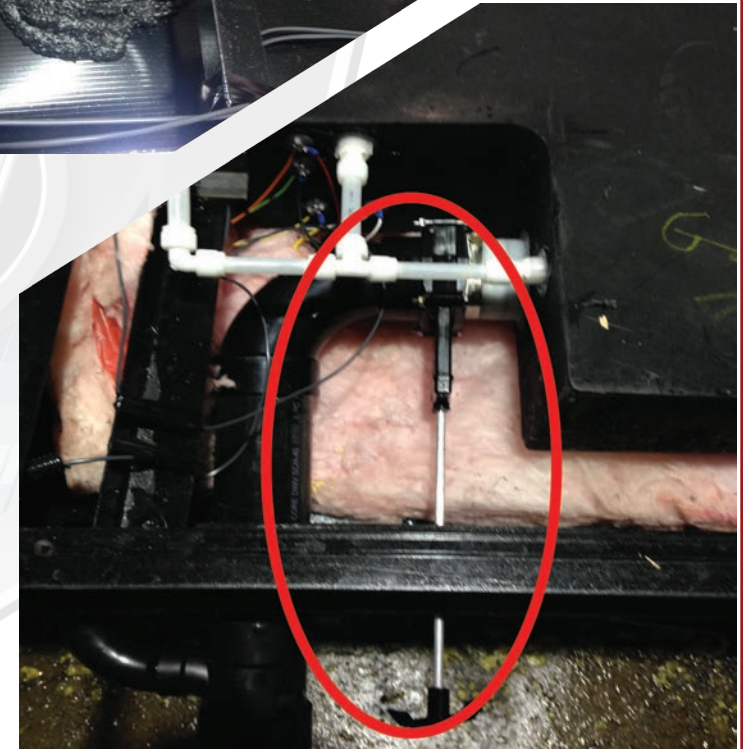
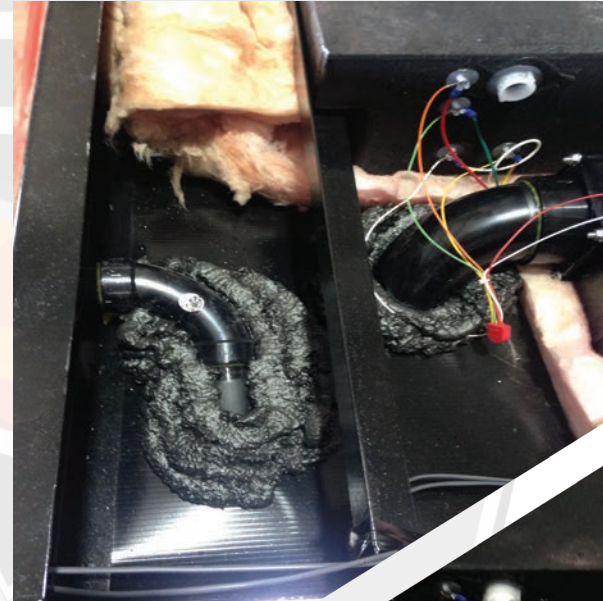

ABSOLUTE CONCEPT:

ALL CONDITIONS - FOUR SEASONS

Maximum Insulation

- Maximum Insulation types are used in all areas
- Insulations types we use:
 - EPS Rigid Block Foam (R7 Rating)
 - R7 & R11 Fiberglass Batten Rolls
 - Thermal Foil Reflective Blankets (TFRB)

Expanded Poly Styrene (EPS) Rigid Block Foam Insulation

- Closed cell, lightweight, and rigid
- No physical or chemical breakdowns over time - no bowing, no shrinkage, no loss of strength
- Closed cell structure prevents capillary absorption of water and moisture
- Does not sustain mold or mildew growth
- Green Material: 100% recyclable and will not contaminate the surrounding environment

Fiberglass Batten Insulation

- Used under floors, tanks and in ceilings
- 100% Formaldehyde free
- Arctic Fox, Fox Mountain & Desert Fox
 - R7 Walls & Floors
 - R18 Ceiling (R7 + R11 and TFRB)
- Nash
 - R7 Walls & Floors
 - R14 Ceiling (R7 + R7 and TFRB)

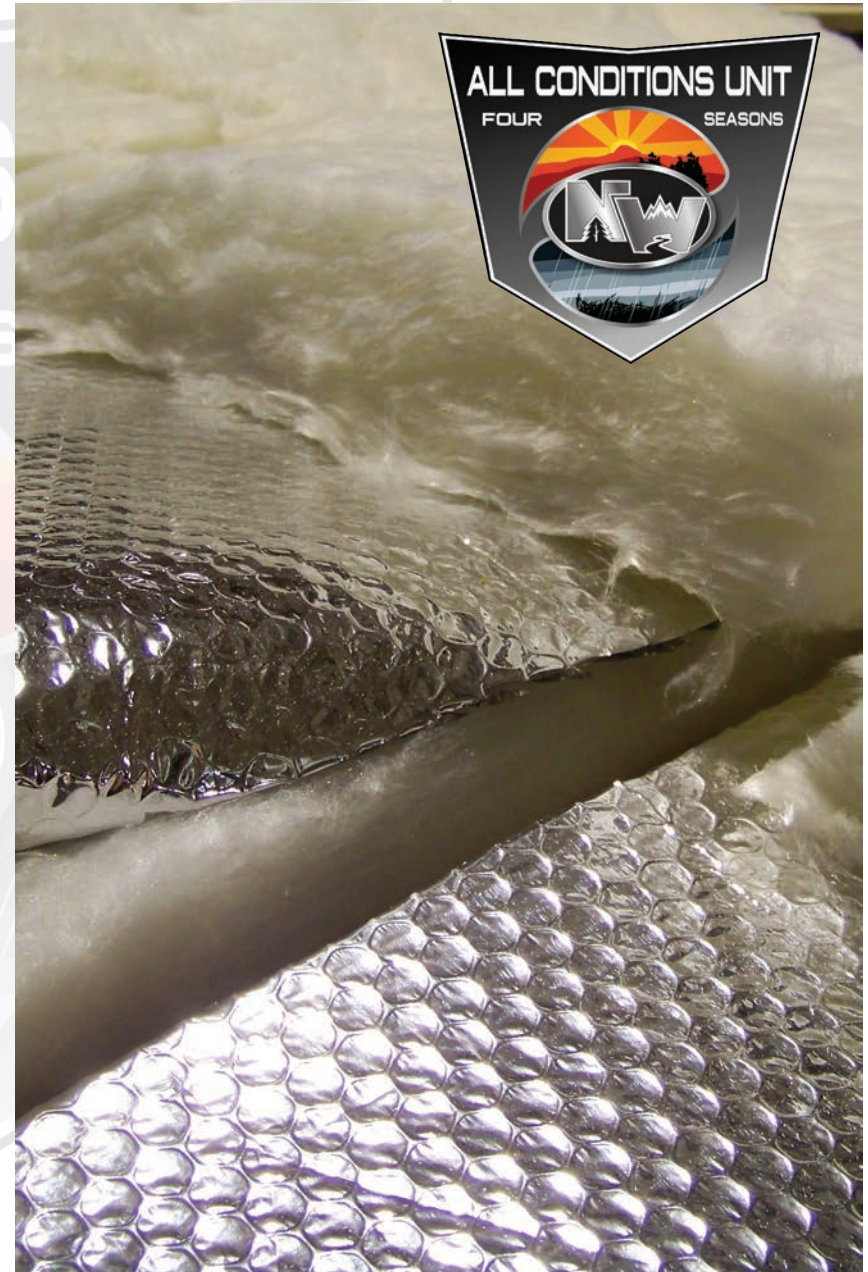

ABSOLUTE CONCEPT:

ALL CONDITIONS - FOUR SEASONS

TFRB (Thermal Foil Reflective Blanket)

Reflective foil insulation reflects 97% of radiant heat to keep you toasty warm in the winter and cool in the summer

- Is an ideal convection/vapor barrier
- Will not get wet and will not mildew
- Blanket design helps to eliminate unwanted drafts
- Insulates flush floor slideout floors
- Insulates flush floor slideout floors
- Located between two layers of batten insulation in the roof structure

THERMAL FOIL REFLECTIVE BLANKET

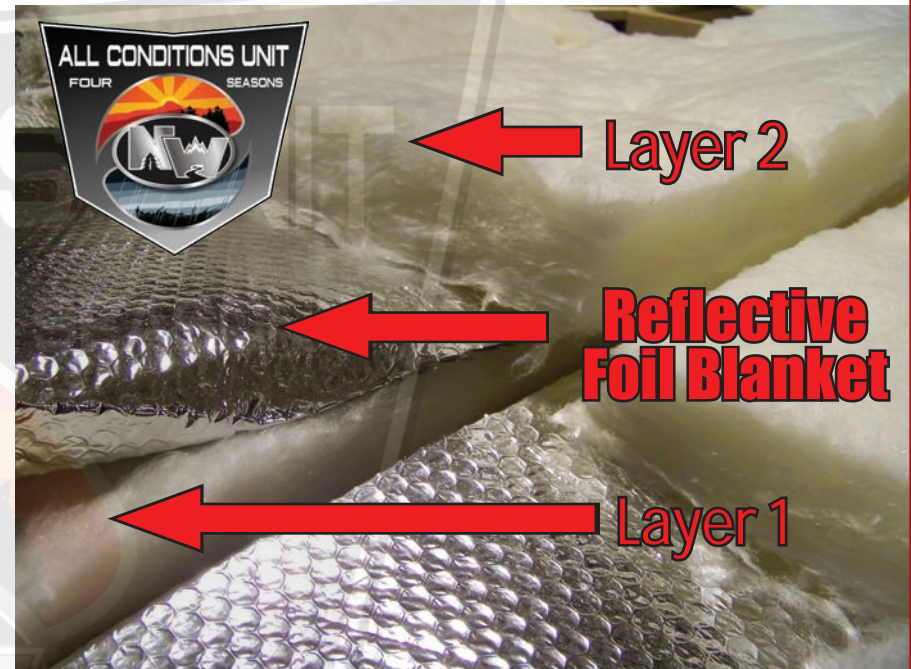
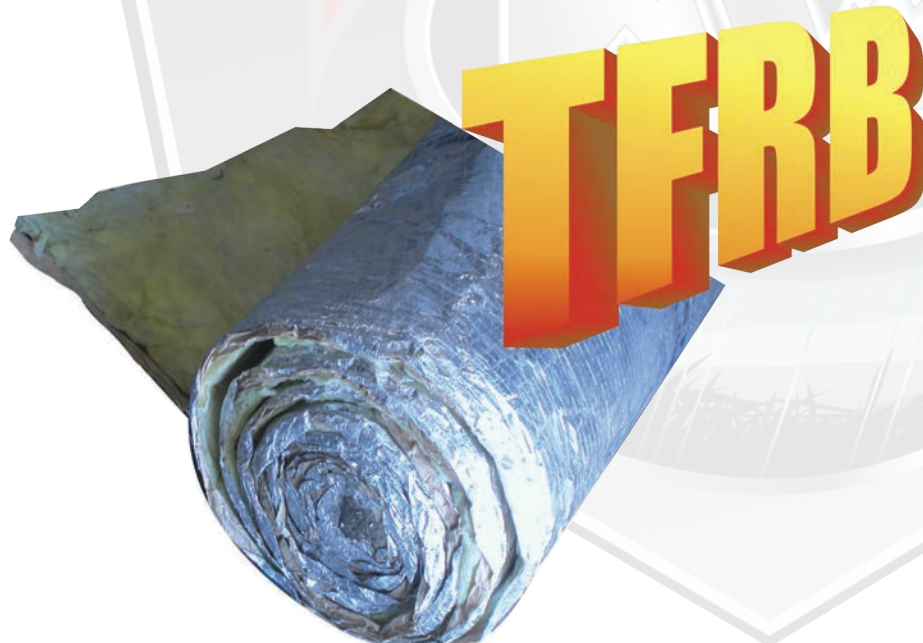

ABSOLUTE CONCEPT:

ALL CONDITIONS - FOUR SEASONS

Quality Seals

- Compression Seals:
 - All entry doors
 - All compartment doors
- 4 Slideouts Seals:
 - Compression Seals behind slide flange
 - Compression seal on exterior wall
 - Compression seal on inside fascia flange
 - Wiper seal maintains seal in all positions



All Conditions Construction Features

- Digital thermostat
- Insulated entry door
- 1" thick insulated compartment doors
- Thermal Pane windows (Standard on All)
- 12-Volt & 110 Volt Holding Tank Heaters available on every model
- Water Heater By-Pass for ease of winterization



Rigid Wiper Seal

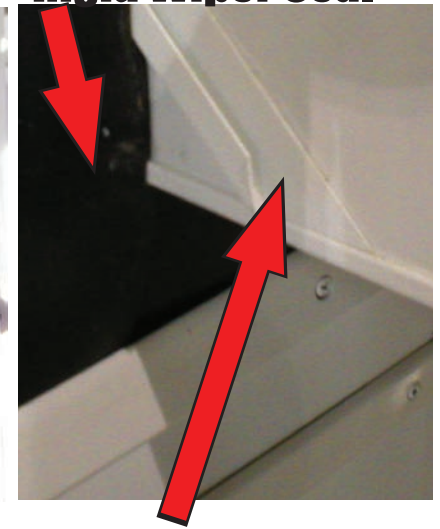

ABSOLUTE CONCEPT:

NW BONDED ROOF TRUSS SYSTEM

A TRUE FULL WALK-ON ROOF

The Northwood Bonded Roof Truss System

We fasten & glue bond all of the structural components of the roof together to form a single unit. The ceiling luan, the wooden Cathedral-Arch trusses, and the marine-grade plywood roof deck are unified into a single roof structure. This ties together the sidewalls, front, and rear of the RV.

Top Quality Materials

- We use premium and Select Structure wood components
- Formaldehyde-free plywoods
- Formaldehyde-free insulation
- Continuous sheet of thick Tufflex PVC membrane roofing

Ample Roof Slope



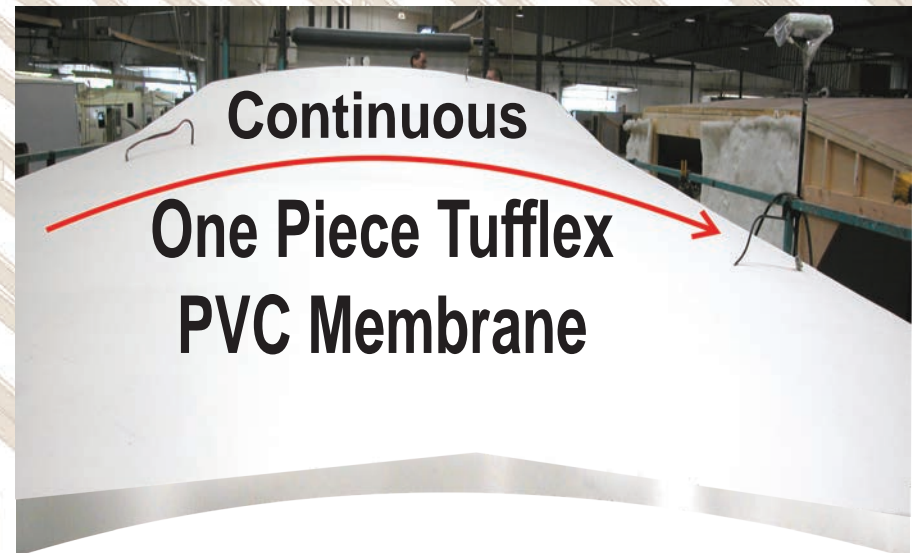
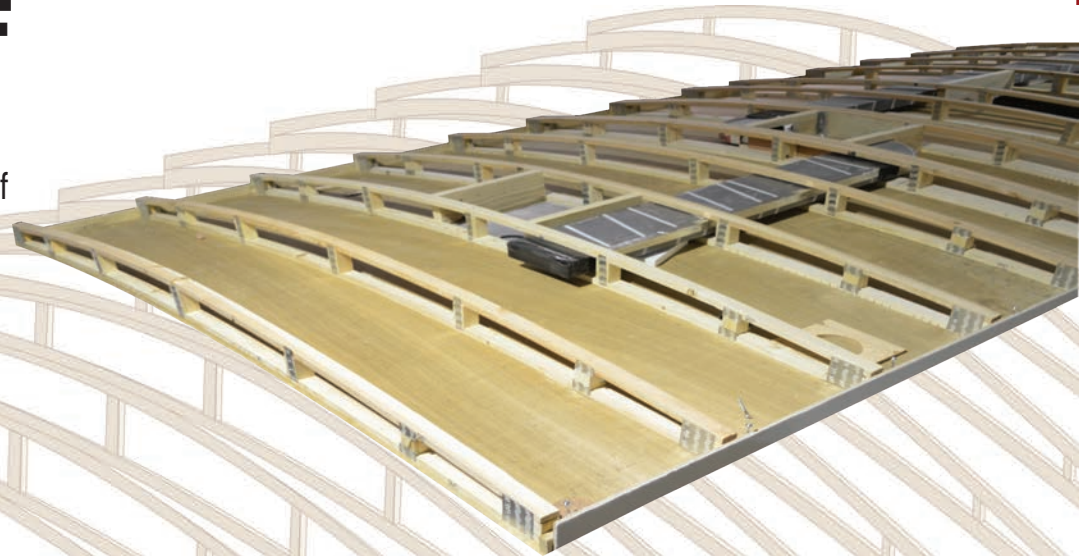





- The 5-1/2 inch center height of our Cathedral-Arch roof trusses
- Increases the structural strength
- Efficiently eliminates the potential of standing water
- Maximizes interior headroom



ABSOLUTE CONCEPT:

VACUUM BONDED SOLID FOAM ROOF

NORTHWOOD ROOF TRUSS SYSTEM

-  1. Heavy-gauge Tufflex PVC one-piece roof membrane
-  2. 3/8" marine-grade plywood decking (screwed, nailed and glued to trusses)
-  3. "TFRB" thermal foil (R15) reflective blanket insulation
-  4. Multiple layer fiberglass insulation (R18)
-  5. Cathedral-Arch wooden roof trusses (solid wood - not OSB)
-  6. Interior lamination grade lauan ceiling (bonded to trusses)
-  7. Snap batten track molding physically captures adjoining panels
-  8. Marine-grade ceiling carpet headliner (Arctic Fox 5th wheels only)

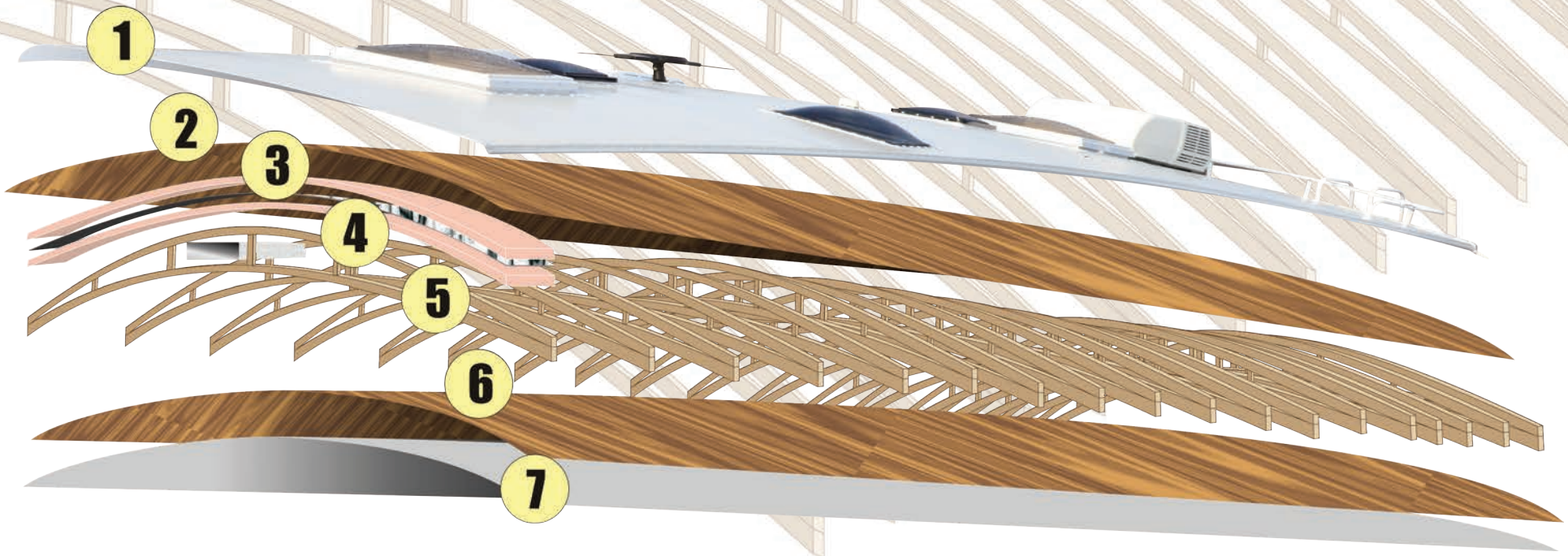

ABSOLUTE FOCUS:

ALUMINUM WALL CONSTRUCTION

Northwood's Aluminum SuperStructure

- Northwood's on-site lamination facility builds all of our Aluminum SuperStructure wall systems. We use thick-wall, aircraft grade aluminum (up to 1/8" thick), fully welded joints, R7 2 lb. virgin block foam, steel bonderizers and hot melt urethane adhesive applied under controlled atmospheric conditions, bonded under 8,000 pounds of pressure and trimmed by a computer controlled router for a precise fit on every wall section.

Small Steps to Make a Big Difference

- Solid Core Anchor Blocking is located at key placements where walls join to the roof, floor and other interior walls
- Continuous bead welds are applied at every joint
- Climate control - Temperature and Humidity are both continually regulated to maintain the optimal conditions for hot melt urethane application and temperature of the components
- Machine Applied Adhesives - the exact thickness of adhesive is applied automatically to every component to provide maximum bond
- Critical Time Considerations - Strict guidelines are maintained for the time from glue application to the compression of the wall system for the best possible adhesion.

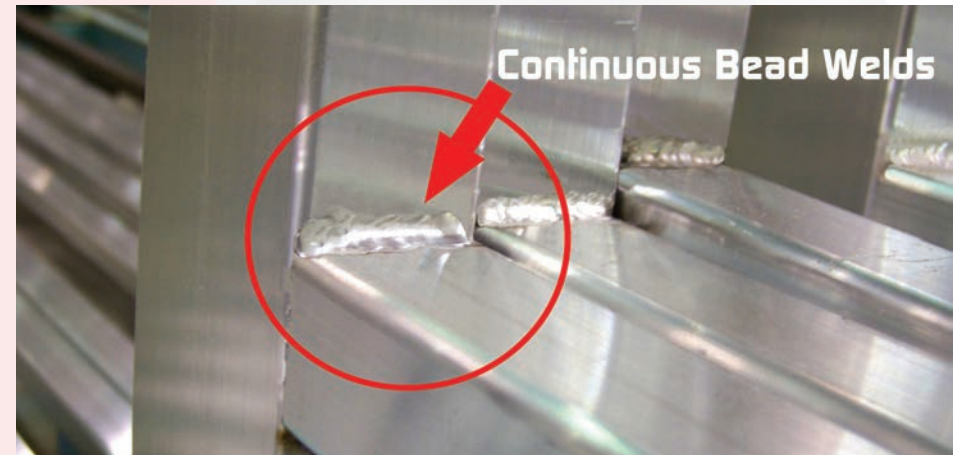

ABSOLUTE FOCUS:

ALUMINUM SUPERSTRUCTURE

Aluminum Superstructure

- The structural frame of the wall is comprised of aircraft grade tubular aluminum with wall thickness of up to 1/8 inch thick
- To achieve the greatest strength and dependability possible, we fill key framing components with solid wood blocking - this ensures that when we screw into these frames, the screws are anchoring into solid wood, not an empty aluminum tube
- The next step is to fill the voids between the aluminum framing with EPS closed cell, block foam insulation - this premium foam block provides structure and a dependable medium ideal for lamination
- Structural reinforcement is added where needed to hang cabinets, etc. by placing bonderized (anti-corrosive) metal braces which are inset into the wall



**ABSOLUTE
ADVANTAGE**
SOLID CONSTRUCTION
THROUGH AND THROUGH!

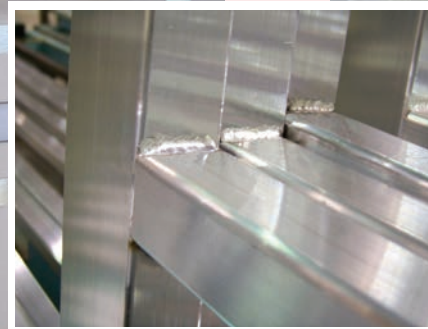

ABSOLUTE FOCUS:

ALUMINUM SUPERSTRUCTURE

Aluminum Superstructure (Continued)

- The exterior siding is a seamless panel of fiberglass that has been Corona treated to enhance its lamination properties
- To increase the structural integrity of this exterior panel, we apply one or two layers of premium luaun plywood backer using environmentally controlled, thermal urethane construction adhesives
- Layers are subjected to the extreme pressure of 8,000 lbs/square inch with our compression-roll lamination processor, thus bonding these layers together to form a single component
- The interior siding is a finish grade luaun plywood that has been laminated with a decorative, vinyl coating
- The result is a one-piece wall structure that will withstand the battering elements and their penetrating temperatures
- CNC router (computer numerical controlled) is a hands-free operation in which the computer routs out any required access points for doors, windows, compartments, etc., with repeatable precision and quality

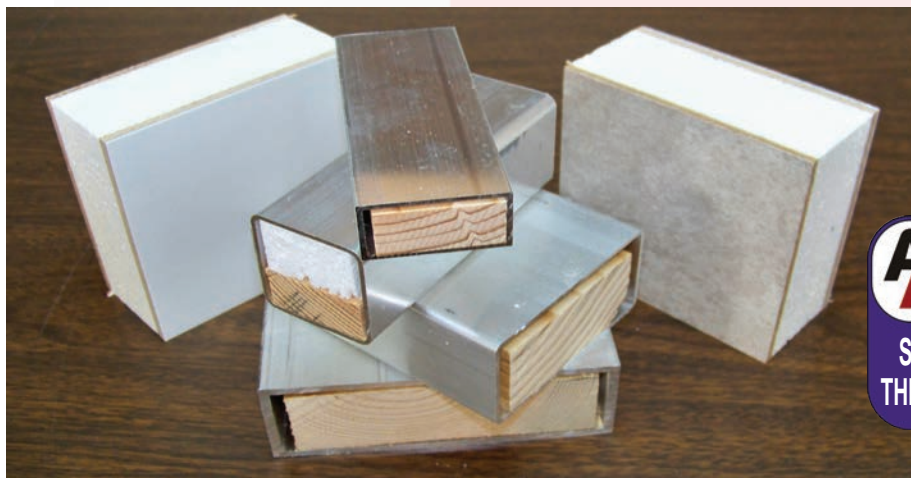

**ABSOLUTE
ADVANTAGE**
SOLID CONSTRUCTION
THROUGH AND THROUGH!

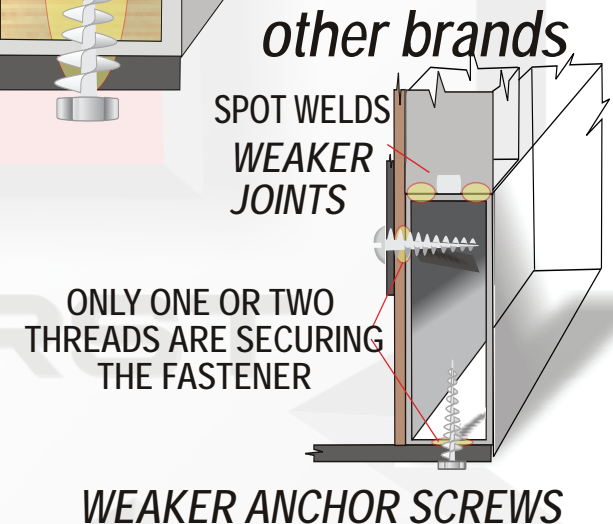
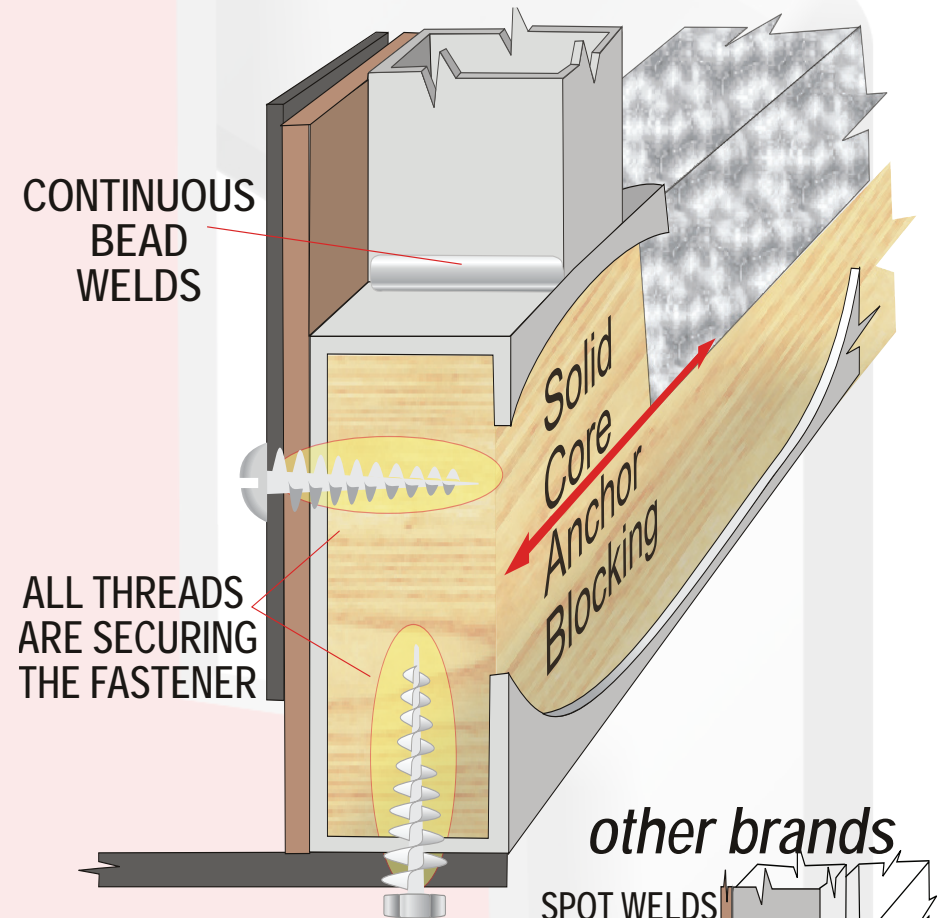

ABSOLUTE FOCUS:

UNIFIED FLOOR CONSTRUCTION

Northwood Unified Floor

Our Floor System is designed to provide significant strength while it protects the bottom of the trailer from penetrating cold and moisture

- Floor joists and framing utilize Select Structure grade lumber
- Pre-assembled wiring harnesses for serviceable, dependable power
- Custom crimp-sealed sheet metal heating ducts
- R7 batten fiberglass insulation
- Premium 5/8" structural tongue-and-groove plywood, wood glue, and adhesive-coated, premium construction fasteners
- The top surface is sanded prior to the installation of our selected residential grade floor covering that resists cold cracking in sub-zero conditions and will hold up to years of use
- Woven RV Under Siding Protection - a seamless durable, waterproof weather barrier wrapped to overlap the front, rear, and sides of the floor and allows the floor to 'breathe'
- The entire structure is then carriage bolted to the outriggers of the chassis to create a strong foundation

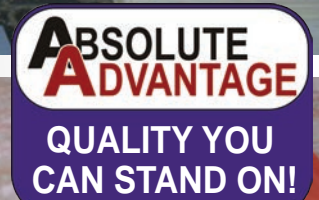
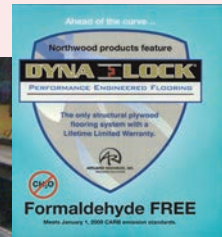

ABSOLUTE FOCUS:

CABINETS AND DRAWERS

Northwood Cabinets

- Residential style face frame construction
- All cabinets frames are screwed and glued together
- Overhead cabinets tie into wall & ceiling when appropriate
- All floor cabinets are anchored to walls & floors
- Cabinet installation adds strength to the entire coach

Doors and Drawers

- Residential quality hard wood door frames and drawer fronts
- Durable, luxury finishes
- All door frames utilize mortise and tenon joints and are glued together

Components and Construction

- All drawer bottoms are supported by dado grooves in the sides of the drawers and feature full-extension, 100 lb. rated, roller bearing drawer guides that allow full access to the drawer



**ABSOLUTE
ADVANTAGE**

**STURDY CABINETS
THAT STAND UP TO
ROAD RIGOR!**



ABSOLUTE FOCUS:

MAXIMIZED STORAGE SPACE

Interior Storage in most models includes:

- Maximized storage capacity in every floor plan that we build
- Many designs offer combinations of storage considerations such as:



Dozens of Drawers and Cabinets in the Kitchens of most models



Under Dinette
Over Head

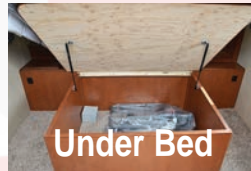

Under Bed



Bonus Storage
Around Fridge



Pantry



Wardrobe



Above Counter

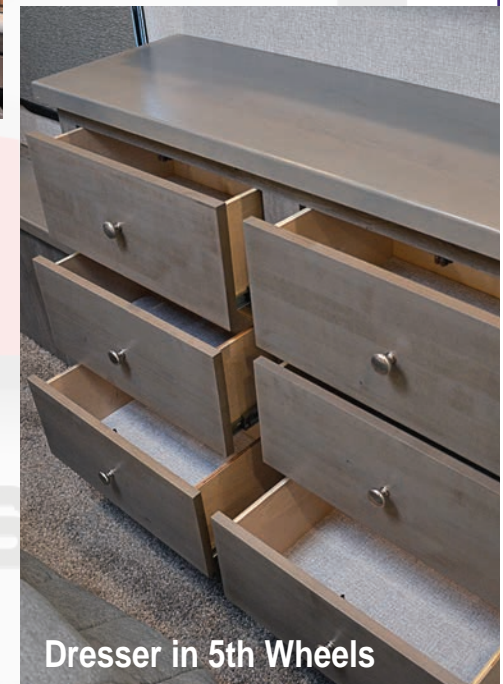

Dresser in 5th Wheels

ABSOLUTE FOCUS:

MAXIMIZED STORAGE SPACE

Exterior Storage in most models includes:

- 1" thick, insulated compartment doors
- Magnetic catches
- Arctic Fox models feature SLAM Latches
- Automotive Compression Seals
- All Arctic Fox 5th wheel models feature large pass-thru storage in the front of the coach that also include:
 - Independently switched, LED cargo lights
 - Northwood Convenience Center compartment



**ABSOLUTE
ADVANTAGE**
MAX STORAGE FOR
A MAX EXPERIENCE!



ABSOLUTE FOCUS:

A ROOM WITH A VIEW - WINDOWS

Large-View Tinted Windows

- Northwood large-view windows allow in more light, brightening the interior of every coach and offer a “wide-open” feel
- Window tinting reduces glare and inhibits the harmful effects of prolonged UV light exposure to the interior of the coach
- Where possible, all windows either slide or provide a crank-out vent to allow for maximum ventilation

Thermal-Pane Windows

- Improved insulation factor
- Improved sound dampening
- Standard on all models



**ABSOLUTE
ADVANTAGE**
BRING THE
OUTSIDE IN!



ABSOLUTE FOCUS:

ECO-FRIENDLY LED AND SOLAR

LED Lighting

All Interior and Exterior Lighting is high efficiency, low amp draw LED

LED
Lighting

**ABSOLUTE
ADVANTAGE**
LONGER LIFE
EFFICIENCY

A Solar Panel is Standard Equipment

2x 200 Watt Future Solutions Solar Panel is mounted on the roof of every Northwood make and model (=400 watts total)

- Made in the USA
- Solar Charge Controller is standard - 40 amp capable of 600 Watts
- Some models wired for additional controller and solar



FUTURE
SOLUTIONS

Additional Solar Panels

Northwood offers optional solar panels in a variety of sizes allowing you to determine what configuration best meets your demands

- No lengthy and expensive stay in the shop to add solar panels
- Solid roof structure allows for the permanent installation directly onto the roof
- All support wiring is installed during construction
- Mix and match up to 600 - 1000 watts depending on model



Sol-X package

Every Northwood Product comes standard with the base module, SolX 4 - an industry leading 400 watt system!

Upgrades are available in 200 watt increments:

- SolX 6 - 600 watts
- SolX 8 - 800 watts
- SolX 10 - 1000 watts



ABSOLUTE FOCUS:

ECO-FRIENDLY LED AND SOLAR

SOLX SOLAR MODULE SYSTEM

FS-200
200 Watt Solar Panel



NORTHWOOD HAS PARTNERED WITH RV SOLAR INDUSTRY LEADER, FUTURE SOLUTIONS, INC. TO CUSTOM DESIGN A PREMIUM SOLAR PLATFORM AND OPTION PACKAGES. THE NORTHWOOD **SOLX SOLAR MODULE SYSTEM** IS EXCLUSIVE, EXPANDABLE AND EXTREME AND AVAILABLE ON ALL MAKES AND MODELS.

EVERY NORTHWOOD PRODUCT COMES STANDARD WITH THE BASE MODULE, SOLX 4 - AN INDUSTRY LEADING 400 WATT SYSTEM! UPGRADES ARE AVAILABLE IN 200 WATT INCREMENTS: SOLX 6 - 600 WATTS; *SOLX 8 - 800 WATTS; AND *SOLX 10 - 1,000 WATTS.

FOR EASE OF IDENTIFYING HOW MUCH ON-BOARD SOLAR THERE IS ON A PARTICULAR UNIT, ONE ONLY HAS TO LOOK AT THE SOLX GRAPHIC LOCATED AT THE DOORWAY AND SEE WHICH NUMERAL IS AFFIXED NEXT TO IT: 4; 6; 8; OR 10.



INDICATES 400 WATTS OF ON-BOARD SOLAR

ABSOLUTE FOCUS:

ECO-FRIENDLY LED AND SOLAR

EACH SOLAR CHARGING CIRCUIT HAS BEEN UPGRADED TO INCLUDE A PV DISCONNECT AND HD RESETTABLE CHARGING BREAKER TO INCREASE SAFETY AND SERVICE CAPABILITY OF THE SYSTEM.

SCALABLE SOLUTIONS WERE DESIGNED IN SOLX 4 TO 10 (400 WATT UP TO 1000 WATT!) PLUG N PLAY SPLITTERS & SOLAR ENTRY PORT ALLOW EASY UPGRADES BY THE DEALER OR CONSUMER.

SOLAR PANEL FEATURES :

ADVANCED SOLAR CELLS

High-efficiency solar cells ensure high performance of the solar module and create maximum power output.

PANEL LIFE

Under 10% decrease of output power within 10 years and 20% decrease in 20 - 25 years.

ALUMINUM FRAME

Screw-less corner joints provide superior rigidity, with pre-drilled mounting holes for ease of installation.

HIGH-TRANSMISSION GLASS

High-transmission 3.2mm tempered glass (over 92 - 95% transmission). Provides high module efficiency even in diffused light conditions.

SUPERIOR JUNCTION BOX

High quality, weather proof junction box for extended life in harsh conditions.

WEATHER-PROOF DESIGN

High impact resistance to the most severe weather: high wind, driving rain, heavy snow and hail. Moisture-proof and corrosion resistant.

FS-200
200 Watt Solar Panel

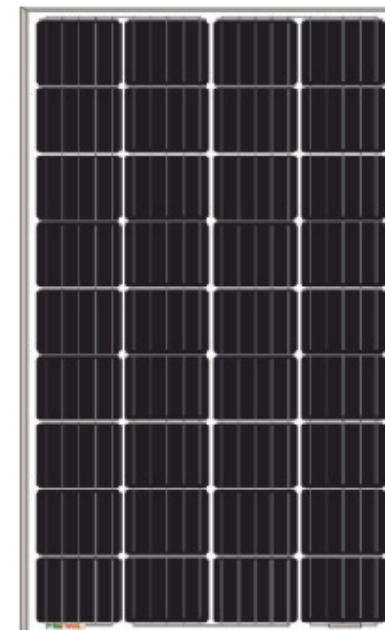

SOLAR CONTROLLER FEATURES :

- High dynamic MPPT (Maximum Power Point Tracking) efficiency up to 99.9%
- High efficiency up to 98%
- Excellent performance at sunrise and low low-light levels
- Wide MPPT operating voltage range
- Self-consumption: Less than 1mA (One milliAmp)
- Optimized charging algorithms for all battery types
- CAN/RV-C Communication + BT Built in ("Smart RV" with Bluetooth)
- Standalone capability + plug n play capabilities w/ Future Solution System integrations
- Supports data logging, remote on/off, App control.
- Lithium charging compatible



Solar Controller

FURRION REFERS

All Northwood makes and models feature Furrion Arctic 12v Stainless Steel Refrigerators. Thanks to innovative designs, these 12v refers provide superior cooling performance at low energy consumption rates. The Furrion Arctic 12v refers boast an extra-large capacity delivering up to 33% more storage space than competitors' refers that have the same size outer dimensions. The SolX 4 Solar Module System with its 400 watts of available solar that is standard on every, Northwood make and model, making the pairing of 12v refrigeration a natural fit for maximizing off-grid and camping adventures. Less power consumption reduces the burden on the power system, allowing the fridge to run throughout a trip.

Furrion's Vibrosmart technology and door latching systems help with bumpy roads, while Climasmart allows the refrigerator to withstand extreme temperatures and weather conditions. Furrion Arctic fridges also offer the option to switch to off-grid mode for energy saving and boondocking. Incredibly, Furrion's powerful cooling technology enables freezers to reach temperatures as low as -11.2 degrees Fahrenheit! Combined with well-insulated walls, food will stay fresher and liquids cooler longer for the duration of a trip even in the event of minor power outage.

Furrion Arctic
12V Refrigerator



12V REFER FEATURES :

DESIGNED FOR PERFORMANCE

Simple radiated cooling design provides the fastest cool down rate by preventing air flow blockage that are common in other 12Volt refrigerators.

DESIGNED FOR EFFICIENCY

Top of the line 12Volt compressor technology provides maximum efficiency to provide the best off-grid experience.

DESIGNED FOR USABILITY

12Volt compressor allows for travel and cooling anywhere, including in transit, high elevation and uneven terrain, without the worry of propane usage and combustible flame as found in other RV refrigerators.

CAPACITIES AND FLOORPLANS:

Arctic Fox Campers

8cu' - (811, 865, 990, 992, 1150)

10cu' - (1140)

Grande Ronde

10cu' (27-5L, 29-5K, 29-5T, 32-5M)

14cu' (30-5RD, 35-5Z) (29-5K, 29-5T, 32-5M option)

North Fork

10cu' (22G, 25R, 25W, 25Y, 28F, 29RK, 32A)

Desert Fox

10cu' (24AS, 27FS)

Fox Mountain

10cu' (235RLS, 265RDS)

Wolf Creek

8cu' (850, 890)

ABSOLUTE FOCUS:

GENERATORS

Generators and Generator Ready

- Every Desert Fox toy hauler is equipped with a standard, gasoline operated 4KW Cummins Onan generator
- Every Arctic Fox fifth wheel, Nash travel Trailer and Fox Mountain fifth wheel is pre-wired and pre-plumbed for an optional Cummins Onan LPG generator
- Cummins Onan LPG generators can be equipped optionally on the 22G, 25R and 28F AF North Fork travel trailers
- Factory installed generator includes a built-in transfer switch for one-touch operation and includes a push-button start and an hour meter
- All designated generator compartments feature appropriate sound proofing and venting, including a vented compartment door



Why it Matters

Unlike other manufacturers, we have a lot of experience installing generators at the factory. As a result, we make sure that all applicable units have the appropriate electrical and gas plumbing modification completed to facilitate the installation process for our team or for your dealer.



**ABSOLUTE
ADVANTAGE**
BEST IN CLASS
GENERATORS AND
INSTALLATIONS

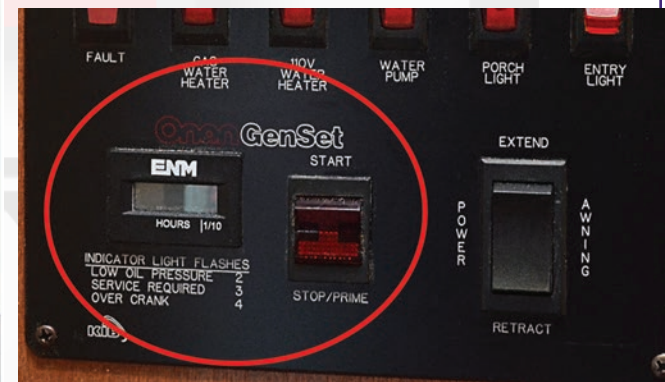

ABSOLUTE FOCUS:

COMFORT & CONVENIENCE FEATURES

Thoughtful and Efficient Exterior Features

- DSI/110 Water Heater- This dual-operation appliance allows you to use the electric function any time you are connected to an electrical outlet
- Two 7 Gallon/ 30 lb LPG Tanks in every AF North Fork, Nash, Fox Mountain and Desert Fox
- Two 10 Gallon/ 40 lb LPG Tanks in Arctic Fox fifth wheels and Nash OTG
- 10 Gallon Option available on all other North Fork & Nash Trailers
- Auto Change Over Regulator on every LPG system
- LPG Quick Disconnect along the patio side of the trailer (most models)
- Steel Battery Racks in every travel trailer and fifth wheel that fit two deep cycle RV batteries. Arctic Fox fifth wheels feature two slide-out, locking battery trays
- Color Coded Knife Valve Handles on every RV
- Black Tank Flush System - Controls odor and prevents build-up
- Leveling Systems (AF Fifth Wheels Standard, AF North Fork and Fox Mountain Optional)
 - One-touch convenience
- Centralized Convenience Center (fifth wheels) - Service hook-ups located in one convenient compartment
- LED Service Lighting is abundant and includes patio lighting, hitch area lighting, road-side service lighting, and compartment lighting
- Electric Awnings - Allows you to extend and retract the patio awning from the comfort of your unit - Automatic dump function that activates if water pools on the awning
- Marine Grade Exterior Speakers
- Satellite Ready - All Northwood units have all the necessary wiring installed at the factory
- 12V Battery Disconnect Switch - Just turn a switch to turn off the 12V system
- Centralized Command Center - We route your high usage systems to a single panel located adjacent to the main entry door, including:
 - Lights (inside and out)
 - Slideout, patio awning
 - Monitors all of your holding tanks
 - Water pump and water heater switches



ABSOLUTE FOCUS:

COMFORT AND CONVENIENCE FEATURES

Thoughtful and Efficient Interior Features

- Bluetooth Enabled Stereo - wirelessly pair your electronic devices with the installed stereo and speaker system
- 110V Electrical Outlets conveniently located throughout the RV
- Digital Thermostat - this thermostat operates both the air conditioner and the LP furnace just like your home
- Dream Dinette (Arctic Fox) - large dining surface supported by a wall-mounted, strutted support system provides the easiest conversion from dinette - to bed - to dinette
- USB Charge Ports - Both in the living area and the bedroom
- TruRest Comfort Inner Spring Mattress - A Northwood exclusive is standard on all makes and models with dedicated bedrooms featuring a pillow top cushion (both top and bottom)
- UltraDeck Sleep System (AF 5th Wheels) adds an additional 33% of cushion
- Strut-assisted storage capacity under the bed platform
- Porcelain Bowl Toilet - Easier to keep clean and residential quality
- 2nd Water Pump Switch in bathroom (Arctic Fox)
- 12 Volt Stainless Steel Refrigerator



**ABSOLUTE
ADVANTAGE**
COMFORT AND STYLE
THAT HITS HOME!



Safety Features

- Code compliance - American National Standards Institute (ANSI) and the National Fire Protection Association (NFPA)
- Northwood is CARB compliant and all of our fiberglass and wood products are formaldehyde free
- Smoke Detectors are hard-wired into every Northwood RV
- Fire Extinguishers have been located in close proximity to the kitchen
- LPG Leak Detectors and alarms are installed in every RV
- Carbon Monoxide Detectors and alarms are installed in every RV
- Emergency exit or egress windows are equipped with window screens
- GFI Circuits are wired into the bathroom and kitchen as well as the electrical outlet located outside in the patio area



Safety Beyond the Obvious

- Lend-a-hand - Large entry handle assists in entering and exiting your RV
- Friction hinge on the main entry door for wind resistance
- Standard and dead-bolt locking mechanisms are on every entry door
- Dual, safety chains are welded onto the A-frame of all of our trailers
- A break-away switch designed to electronically activate the trailer brakes installed on every unit
- Large, self-adjusting brakes provide the quick, powerful response that significantly reduces the stopping distance traveled
- Goodyear radial trailer tires are designed specifically for handling and towing heavy loads



PDI (PRE-DELIVERY INSPECTION):

QUALITY INSPECTION

Pre-Delivery Inspection

- The plumbing system check includes all the faucets and connections
- Reverse flood testing to ensure the sinks, tub, and toilet are in proper working order
- Construction and cabinetry are inspected
- Appliances are operated, power sources checked, and all electronic components are tested
- The LPG system is pressurized and maintained at an elevated pressure throughout the entire system
- Electrical systems are surge tested by overcharging the circuits to identify any issues
- The 12V system is surge tested with 600 volts and the 120V system is surge tested to 1080 volts
- Seasonal winterizing is included to protect the unit from exposure to cold climates
- All trailers are weighed and documented



ABSOLUTE FOCUS:

OWNER'S WARRANTY

ONE YEAR LIMITED WARRANTY

For travel trailers & 5th wheels manufactured by Northwood Manufacturing
Sold in the United States and Canada

COVERAGE PROVIDED

Your new RV, including the structure, plumbing, heating, and electrical systems, and all appliances and equipment installed by the manufacturer, is warranted under normal use to be free from manufacturing defects in material and workmanship.

This limited warranty extends to the first retail purchaser and his transferee(s) and begins on the date of original retail delivery or the date the RV is first placed into service as a rental, commercial or demonstrator RV (whichever occurs first). This limited warranty extends for a period of one year from such date. Written notice of defects must be given to the selling dealer or the manufacturer not later than ten (10) days after the expiration of the applicable limited warranty. Warranty repairs, if required, will be made without charge after your RV is taken to the dealer or manufacturing plant location.

OWNER'S OBLIGATIONS: The owner is responsible for normal maintenance as described in the Owner's Manual; however, minor adjustments (such as adjustments to the interior or exterior doors, LP regulator pressure, cabinet latches, TV antenna control, etc.) will be performed by the dealer during the first 90 days of

warranty coverage. Thereafter, such adjustments are the responsibility of the owner as normal maintenance unless required as a direct result of repair or replacement of a defective part under this limited warranty.

DEALER'S OBLIGATIONS: By agreement with the manufacturer, the dealer is obligated to maintain the RV prior to retail sale, to perform a detailed predelivery inspection and to repair or replace any parts necessary to correct defects in material or workmanship.

WHEN A DEALER DOES NOT RESOLVE A PROBLEM: If the dealer is unable or unwilling to resolve a problem which the owner is convinced is covered by this limited warranty, he should contact NORTHWOOD MANUFACTURING at the address listed below and provide the manufacturer with a description in writing of the problem and attempts made to resolve it.

MANUFACTURER'S OBLIGATIONS: Upon receipt of notice of a claim which the dealer was unable or unwilling to resolve, NORTHWOOD MANUFACTURING will repair or replace any parts necessary to correct defects in material or workmanship or will take other appropriate action as may be required.

THIS LIMITED WARRANTY DOES NOT COVER THE FOLLOWING

1. All major appliances, which are covered by the separate warranty of the manufacturer.
2. Damage caused by or related to:
 - A. Accidents, misuse or negligence
 - B. Failure to comply with instructions contained in the Owner's Manual
 - C. Alteration or modification of the RV.
 - D. Environmental conditions (salt, hail, chemicals in the atmosphere, etc.)
3. Normal deterioration due to wear or exposure, i.e., fading of fabrics, drapes, carpet wear, etc.
4. Normal maintenance and service items such as light bulbs, fuses, lubricants, etc.
5. Extra expenses such as transportation to and from dealer or manufacturing plant location, loss of time, loss of pay, loss of use of the RV, inconvenience, commercial loss, towing charges, bus fares, vehicle rental, incidental charges such as telephone calls or lodging bills, or other incidental or consequential damages.

This limited warranty gives you specific legal rights, and you may also have other rights which may vary from state to state.

Dealers or any other persons are not authorized to make modifications to this limited warranty, any additional statements concerning this limited warranty, whether oral or written are not the responsibility of the manufacturer.



Index of Sections



Index
Introduction
Chassis
Four Seasons
Roof
Solar
LED
Windows
Floor Construction
Cabinetry
Wood Frame Construction
Aluminum Construction
Superstructure
Convenience Features
Storage
PDI
Warranty
Generators
Safety
Notes
Furniture
Capacities



Northwood Dealer Training Manual

Northwood Manufacturing, 59948 Downs Rd., PO Box 3359, La Grande, OR 97850 (541) 962-6274 - www.northwoodmfg.com

Photos, drawings, dimensions and weights are presented as accurate but may differ from current production models. We continually upgrade & improve our products and reserve the right to change any specifications without notice. Please see your authorized Northwood dealer for updated information.